



HANDBOOK

HY-03 TBU

HY-03

Automatic analogue TBU with ringing detector, free standing

HY-03 (US)

Automatic analogue TBU with ringing detector, free standing US Version

HY-03S

Automatic analogue TBU with ringing detector, 19" rack mounted

HY-03S (US)

Automatic analogue TBU with ringing detector, 19" rack mounted US Version

HY-03T

Twin automatic analogue TBU with ringing detector, 19" rack mounted

HY-03T (US)

Twin automatic analogue TBU with ringing detector, 19" rack mounted, US Version

HY-03DTD

Dial tone detect add-on board for HY-03 range



Manufacturers of audio & video products for radio & TV broadcasters

SONIFEX

For the latest Sonifex handbook information please visit the Sonifex website at www.sonifex.co.uk

This handbook is for use with the following products :

- HY-03 Automatic analogue TBU with ringing detector, free standing
- HY-03 (US) Automatic analogue TBU with ringing detector, free standing US Version
- HY-03S Automatic analogue TBU with ringing detector, 19" rack mounted
- HY-03S (US) Automatic analogue TBU with ringing detector, 19" rack mounted US Version
- HY-03T Twin automatic analogue TBU with ringing detector, 19" rack mounted
- HY-03T (US) Twin automatic analogue TBU with ringing detector, 19" rack mounted, US Version
- HY-03DTD Dial tone detect add-on board for HY-03 range

AW10932H, Stock Code: 30-148

©Sonifex Ltd, 2018

All Rights Reserved

Revision 1.08, October 2018

Sonifex Ltd, 61, Station Road, Irthlingborough,
Northants, NN9 5QE, England.

Tel: +44 (0)1933 650 700

Fax: +44 (0)1933 650 726

Email: sales@sonifex.co.uk

Website: <http://www.sonifex.co.uk>

Information in this document is subject to change without notice and does not represent a commitment on the part of the vendor. Sonifex Ltd shall not be liable for any loss or damage whatsoever arising from the use of information or any error contained in this manual.

No part of this manual may be reproduced or transmitted in any form or by any means, electronic or mechanical, including photocopying, recording, information storage and retrieval systems, for any purpose other than the purchaser's personal use, without the express written permission of Sonifex Ltd. Unless otherwise noted, all names of companies, products and persons contained herein are part of a completely fictitious adaptation and are designed solely to document the use of Sonifex product.

Made in the UK by **SONIFEX**

Contents

Product Warranty - 2 Year Extended	i
Sonifex Warranty & Liability Terms & Conditions	i
1. Definitions	i
2. Warranty	i
Unpacking Your Product	ii
Repairs & Returns	iii
CE Conformity	iii
Safety & Installation of Mains Operated Equipment	iii
Voltage Setting Checks	iii
Fuse Rating	iii
Power Cable & Connection	iii
Opening the HY-03	iv
WEEE Directive	iv
Atmosphere/Environment	iv
1 Introduction	1
What is a Telephone Hybrid?	1
Integrated Ringing Detector	1
Available Formats	2
Installing the HY-03 TBU	3
Using the HY-03	4
Receiving a Call	4
Making a Call	5
FAQ (Frequently Asked Questions)	5
2 Configuration & Controls	7
Front Panel Controls	7
Power LED Indicator	7
Line Connect Switch	7
Rear Panel Controls	7
Adjusting the Output Level	8
Adjusting the Microphone Gain Level	8
Mic/Line Input Select Switch	8
Remote Mode Select Switch	8
Configuration Settings Switches	8
Dial Tone Disconnect Enable - SW1	8
K-Break Disconnect Enable - SW2 and JP4	8
Line Polarity Reversal Disconnect Enable - SW2 and JP5	9
Input/Output Mix Enable - SW3	9
Ring Detector (Auto Answer) Enable - SW4	9
Mains Voltage Selector Switch	9

HY-03 Internal Controls & Adjustments	9	Figures	
Setting the Number of Rings for The Ringing Detector	9	Figure 1-1 : HY-03 & HY-03 US Front & Rear	2
Switching the Noise Gate On/Off	10	Figure 1-2 : HY-03S & HY-03S US Front & Rear	2
Adjusting the Noise Gate Threshold	10	Figure 1-3: HY-03T & HY-03T US Front & Rear	3
Using the Dial Tone Disconnect Option	10	Figure 1-4: HY-03 User Connections	3
3 Technical Specification	13	Figure 2-1: Front Panel Controls	7
HY-03 Connection Details	13	Figure 2-2 : Rear Panel Controls	7
Line Output	13	Figure 2-3 : Configuration Settings Switches	8
Mic/Line Input	13	Figure 2-4 : HY-03 Preset Controls and Alignments	9
Remotes	13	Figure 2-5 : Jumper settings on the HY-03DTD board	10
Telephone Handset	14	Table D : Dial tone disconnect options	12
Telephone Line	14	Figure 3-1 : HY-03 Rear Panel Connections	13
Mains Input	14		
Protective Earth Terminal	14		
Technical Specification	14		
Physical Specification	15		
Accessories	15		
Approvals Information	16		
Manufacturer	16		
Equipment Type	16		
BABT Approval Numbers	16		
Functions	16		
Specified Systems	16		
Ringer Equivalence Number	16		
Conditions	16		
Series Connection	16		
Facilities	17		
Statutory Mark	17		

SONIFEX

Register Online for an Extended 2 Year Warranty

As standard, Sonifex products are supplied with a 1 year back to base warranty.

If you register the product online, you can increase your product warranty to 2 years and we can also keep you informed of any product design improvements or modifications.

Product: _____

Serial No: _____

To register your product, please go online to www.sonifex.co.uk/register

Product Warranty - 2 Year Extended

As standard, Sonifex products are supplied with a 1 year back to base warranty. In order to register the date of purchase and so that we can keep you informed of any product design improvements or modifications, it is important to complete the warranty registration online. Additionally, if you register the product on the Sonifex website, you can increase your product warranty to 2 years. Go to the Sonifex website at: www.sonifex.co.uk/ register to apply for your 2 year warranty.

Sonifex Warranty & Liability Terms & Conditions

1. Definitions

‘the Company’ means Sonifex Ltd and where relevant includes companies within the same group of companies as Sonifex Limited.

‘the Goods’ means the goods or any part thereof supplied by the Company and where relevant includes: work carried out by the Company on items supplied by the Purchaser; services supplied by the Company; and software supplied by the Company.

‘the Purchaser’ means the person or organisation who buys or has agreed to buy the Goods.

‘the Price’ means the Price of the Goods and any other charges incurred by the Company in the supply of the Goods.

‘the Warranty Term’ is the length of the product warranty which is usually 12 months from the date of despatch; except when the product has been registered at the Sonifex website when the Warranty Term is 24 months from the date of despatch.

‘the Contract’ means the quotation, these Conditions of Sale and any other document incorporated in a contract between the Company and the

Purchaser.

This is the entire Contract between the parties relating to the subject matter hereof and may not be changed or terminated except in writing in accordance with the provisions of this Contract. A reference to the consent, acknowledgement, authority or agreement of the Company means in writing and only by a director of the Company.

2. Warranty

- a. The Company agrees to repair or (at its discretion) replace Goods which are found to be defective (fair wear and tear excepted) and which are returned to the Company within the Warranty Term provided that each of the following are satisfied:
 - i. notification of any defect is given to the Company immediately upon its becoming apparent to the Purchaser;
 - ii. the Goods have only been operated under normal operating conditions and have only been subject to normal use (and in particular the Goods must have been correctly connected and must not have been subject to high voltage or to ionising radiation and must not have been used contrary to the Company’s technical recommendations);
 - iii. the Goods are returned to the Company’s premises at the Purchaser’s expense;
 - iv. any Goods or parts of Goods replaced shall become the property of the Company;
 - v. no work whatsoever (other than normal and proper maintenance) has been carried out to the Goods or any part of the Goods without the Company’s prior written consent;
 - vi. the defect has not arisen from a design made, furnished or specified by the Purchaser;

- vii. the Goods have been assembled or incorporated into other goods only in accordance with any instructions issued by the Company;
 - viii. the defect has not arisen from a design modified by the Purchaser;
 - ix. the defect has not arisen from an item manufactured by a person other than the Company. In respect of any item manufactured by a person other than the Company, the Purchaser shall only be entitled to the benefit of any warranty or guarantee provided by such manufacturer to the Company.
- b. In respect of computer software supplied by the Company the Company does not warrant that the use of the software will be uninterrupted or error free.
- c. The Company accepts liability:
- (i) for death or personal injury to the extent that it results from the negligence of the Company, its employees (whilst in the course of their employment) or its agents (in the course of the agency);
 - (ii) for any breach by the Company of any statutory undertaking as to title, quiet possession and freedom from encumbrance.
- d. Subject to conditions (a) and (c) from the time of despatch of the Goods from the Company's premises the Purchaser shall be responsible for any defect in the Goods or loss, damage, nuisance or interference whatsoever consequential economic or otherwise or wastage of material resulting from or caused by or to the Goods. In particular the Company shall not be liable for any loss of profits or other economic losses. The Company accordingly excludes all liability for the same.
- e. At the request and expense of the Purchaser the Company will test the Goods to ascertain performance levels and provide a report of the results of that test. The report will be accurate at the time of the test, to the best of the belief and knowledge of the Company, and the Company accepts no liability in respect of its accuracy beyond that set out in Condition (a).
- f. Subject to Condition (e) no representation, condition, warranty or other term, express or implied (by statute or otherwise) is given by the Company that the Goods are of any particular quality or standard or will enable the Purchaser to attain any particular performance or result, or will be suitable for any particular purpose or use under specific conditions or will provide any particular capacity, notwithstanding that the requirement for such performance, result or capacity or that such particular purpose or conditions may have been known (or ought to have been known) to the Company, its employees or agents.
- g. (i) To the extent that the Company is held legally liable to the Purchaser for any single breach of contract, tort, representation or other act or default, the Company's liability for the same shall not exceed the price of the Goods.
- (ii) The restriction of liability in Condition (g)(i) shall not apply to any liability accepted by the Seller in Condition (c).
- h. Where the Goods are sold under a consumer transaction (as defined by the Consumer Transactions (Restrictions on Statements) Order 1976) the statutory rights of the Purchaser are not affected by these Conditions of Sale.

Unpacking Your Product

Each product is shipped in protective packaging and should be inspected for damage before use. If there is any transit damage take pictures of the product packaging and notify the carrier immediately with all the relevant details of the shipment. Packing materials should be kept for inspection and also for if the product needs to be returned.

The product is shipped with the following equipment so please check to ensure that you have all of the items below. If anything is missing, please contact the supplier of your equipment immediately.

Item	Quantity
Product unit	1
IEC mains lead fitted with moulded mains plug	1
Handbook and warranty card	1

If you require a different power lead, please let us know when ordering the product.

Repairs & Returns

Please contact Sonifex or your supplier if you have any problems with your Sonifex product. Email technical.support@sonifex.co.uk for the repair/upgrade/returns procedure, or for support & questions regarding the product operation.

CE Conformity

The products in this manual comply with the essential requirements of the relevant European health, safety and environmental protection legislation.

The technical justification file for this product is available at Sonifex Ltd.

The declaration of conformity can be found at:
<http://www.sonifex.co.uk/declarations>

Safety & Installation of Mains Operated Equipment

There are no user serviceable parts inside the equipment. If you should ever need to look inside the unit, always disconnect the mains supply before removing the equipment covers. The cover is connected to earth by means of the fixing screws. It is essential to maintain this earth/ground connection to ensure a safe operating environment and provide electromagnetic shielding.

Voltage Setting Checks

Ensure that the machine operating voltage is correct for your mains power supply by checking the box in which your product was supplied. The voltage is shown on the box label. The available voltage settings are 115V, or 230V. Please note that all products are either switchable between 115V and 230V, or have a universal power supply.

Fuse Rating





The product is supplied with a single fuse in the live conducting path of the mains power input. For reasons of safety it is important that the correct rating and type of fuse is used. Incorrectly rated fuses could present a possible fire hazard, under equipment fault conditions. The active fuse is fitted on the outside rear panel of the unit.

Power Cable & Connection

An IEC power connector is supplied with the product which has a moulded plug attached.

The mains plug or IEC power connector is used as the disconnect device. The mains plug and IEC power connector shall remain readily operable to disconnect the apparatus in case of a fault or emergency.

The mains lead is automatically configured for the country that the product is being sent to, from one of:

Territory	Voltage	IEC Lead Type	Image
UK & Middle East	230V	UK 3 pin to IEC lead	
Europe	230V	European Schuko round 2 pin to IEC lead	
USA, Canada and South America	115V	3 flat pin to IEC lead	
Australia & New Zealand	230V	Australasian 3 flat pin to IEC lead	

Connect the equipment in accordance with the connection details and before applying power to the unit, check that the machine has the correct operating voltage for your mains power supply.

This apparatus is of a class I construction. It must be connected to a mains socket outlet with a protective earthing connection.

Important note: If there is an earth/ground terminal on the rear panel of the product then it must be connected to Earth.

Opening the HY-03

If you need to get inside the unit to make configuration adjustments, simply remove the 4 screws in the corners of the rear panel. The rear panel and main PCB will slide backwards out of the metal chassis.

When re-inserting the main PCB, ensure that the PCB edges are in the runners inside the chassis and also that the front panel LED and divert button are in the correct place in the front panel.

Warning : The power must be switched off at the supply or the power lead must be disconnected before attempting to open the unit. Removal of the cover can expose dangerous voltages.

Warning : The telephone line plug should be disconnected from the telecommunications network exchange line before removing the equipment covers.

WEEE Directive



The Waste Electrical and Electronic Equipment (WEEE) Directive was agreed on 13 February 2003, along with the related Directive 2002/95/EC on Restrictions of the use of certain Hazardous Substances in electrical and electronic equipment (RoHS). The Waste Electrical and Electronic Equipment Directive (WEEE) aims to minimise the impacts of electrical and electronic equipment on the environment during their life times and when they become waste. All products manufactured by Sonifex Ltd have the WEEE directive label placed on the case. Sonifex Ltd will be happy to give you information about local organisations that can reprocess the product when it reaches its “end of use”, or alternatively all products that have reached “end of use” can be returned to Sonifex and will be reprocessed correctly free of charge.

Atmosphere/Environment

This apparatus should be installed in an area that is not subject to excessive temperature variation (<0°C, >50°C), moisture, dust or vibration.

This apparatus shall not be exposed to dripping or splashing, and no objects filled with water, such as vases shall be placed on the apparatus.

1 Introduction

The HY-03 is a high quality analogue telephone hybrid, which is suitable for most general telephony applications and is often used in radio and TV stations, bingo halls and dealing floors. The analogue HY-03 telephone hybrid is the replacement for the HY-02, which for many years has set the standard as an excellent value, high quality telephone hybrid.

The HY-03 can be used for any application where a clean telephone signal is required and the line is not subject to delay. The HY-03 retains many of the features of the HY-02 and adds some additional ones. Some of the features of the HY-03 include:

- Fully automatic – adapts to varying line conditions and has automatic signal limiting.
- Local and remote line hold switching – calls can be remotely switched through a mixing console.
- Momentary or permanent latching remotes can be enabled.
- Balanced mic/line input – 10k Ω balanced input selectable for 0dBu clean feed line, or microphone level with adjustable gain.
- Balanced output – 0dBu low impedance balanced output, with output gain adjustment.
- Mixed output – the output can be a mix of the caller and mic/line input signals for recording both sides of the telephone conversation.
- Integrated ring detector – automatic call answering after a pre-determined number of rings.
- Fitted with K-break disconnect (line polarity reversal in the US) detection as standard with an option for dial-tone disconnect (HY-03DTD option).
- Line limiter, bandpass filter and output noise gate with preset threshold providing low distortion crystal clear audio.
- 45dB typical line balance rejection on tone, 28dB on complex waveforms.
- Built in power supply with switchable 115V, or 230V, mains input.
- BAPT approval compliant with European PTT specifications.

What is a Telephone Hybrid?

Telephone hybrids (or telephone balance units, TBUs) provide the interface between professional audio equipment and the public telephone network. They provide protection for your equipment and the public telephone lines, allowing for varying line signals and line conditions. Automatically canceling out the unwanted signal they also facilitate two-way communication down a single telephone line, converting the two-wire telephone signal to a four-wire send and return signal to be linked to a studio mixer, for example.

The hybrid has a telephone line connection and separate terminals for audio input and output from a broadcast mixer, or other professional audio source.

A large proportion of Sonifex hybrids are used in radio and television broadcasting applications for allowing external callers to be connected to the studio mixing console. Most of the other units are supplied to communication operations for allowing extremely effective conversion between four-wire audio circuits and standard telephone lines.

Built to a very high specification, the HY-03 is simple to install and automatically adapts to line conditions and programme content.

Integrated Ringing Detector

Ringing detectors can be used when you need to answer a call automatically, for instance, if a journalist files a report to a tape recorder over a telephone line, the call can be picked up after a set number of rings by the ringing detector. The HY-03 has a built in ring detector that is enabled by one of the configuration settings switches on the rear panel.

Available Formats

The HY-03 analogue telephone hybrids are available in three different formats, each with its own approved, internal power supply :

HY-03 & HY-03 US Automatic analogue TBU with ringing detector, free standing.



Figure 1-1: HY-03 & HY-03 US Front & Rear

HY-03S & HY-03S US Automatic analogue TBU with ringing detector, 1U 19" rack mounted.



Figure 1-2: HY-03S & HY-03S US Front & Rear

HY-03T & HY-03T US Twin automatic analogue TBU with ringing detector, 1U 19" rack mounted.



Figure 1-3: HY-03T & HY-03T US Front & Rear

Installing the HY-03 TBU

Connect the earth and mains power connections as per the information given in the Warranty and Safety Information section of the handbook, and ensure that the mains input voltage selection switch is in the correct position. The hybrid unit should be connected with reference to Figure 1-4.

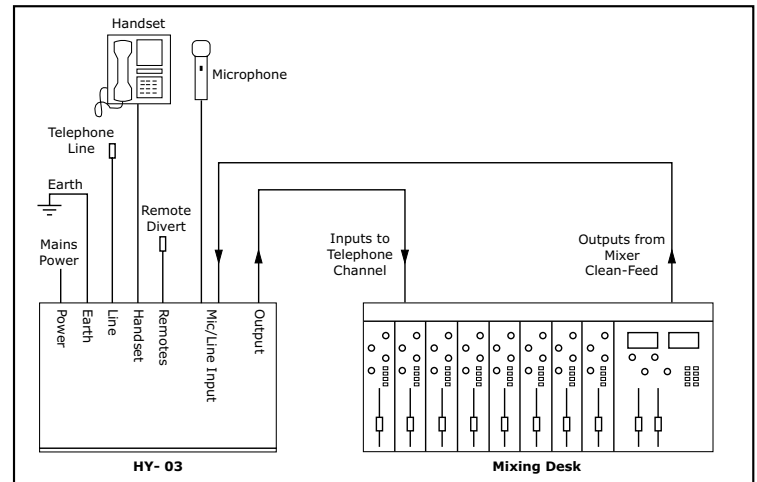

Figure 1-4: HY-03 User Connections

The telephone line socket is connected to the telephone network using the cable provided (either RJ11 to RJ11, or RJ11 to BT plug).

A simple telephone handset can be used to take and make calls when plugged into the equipment handset connector. An adapter is provided if the handset is fitted with a BT plug as standard.

A remote switch may be connected at the Remotes socket in order to control the line connect switch from say, the telco channel of a mixing desk.

Connect the output from the mixing desk “clean-feed” to the mic/line input of the HY-03, with the mic/line input select switch set to “line input”. A clean-feed is a signal produced by a telco module on a mixer which is used as the output to be fed back to a caller on a telephone line. The cleanfeed is a sum of all the other signals which constitute the programme output, except for the caller’s audio (this is so that the caller doesn’t hear him/herself in the ear-piece). A cleanfeed signal will generally be of a better quality than a mix-minus signal.

The characteristics of the mic/line input are determined by the state of the mic/line configuration selection switch. It is a balanced bridging input and in line mode will accept normal signals at 0dBu peaking to +8dBu from a sound mixer clean -feed. In mic mode the unit will accept 200 ohm microphone level signals with a maximum gain of 74dB. It is suitable for a wide range of microphones and the available gain is 74dB to 40dB, which can be adjusted by the mic level pre-set mounted on the rear panel.

The input circuitry to the HY-03 has a very effective limiter, which will prevent high level overloading problems. Ideally, the maximum input level should not exceed +12dBu. This limiter is used for both line and mic input modes.

The output connection will deliver a balanced/floating low impedance signal of 0dBm from the telephone line. The output of the analogue hybrid unit is normally 0dBu from a balanced source of 50 ohms or less across the useful bandwidth of the equipment. The bandwidth is restricted by the

line conditions between 250 Hz and 4 kHz. The output stage is capable of driving into 600 ohm loads at up to +8dBu. Termination of the output is not necessary however and direct connection can be made into the mixer telephone return channel. The output stage has a gain pre-set control, mounted on the rear panel, which may be set to give 0dB signals at the output. In addition an output noise gate operates when the telephone signal is below the noise gate threshold control. This noise gate reduces the output gain by 34dB under no signal conditions eliminating the affects of telephone line cross talk.

The noise gate is factory set to –26dBu to avoid interaction with the equipment null.

Isolation of better than 28dB is created between the input and output connectors when the hybrid unit is functioning on an exchange line.

Note: The earth bond at the screw terminal must be connected to a technical earth to ensure the safe operation of the equipment under all line conditions.

Using the HY-03

Receiving a Call

With the equipment connected as in Figure 1-4 calls may be received and detected by the ringer in the telephone handset. To receive the call, lift the handset and establish contact with the caller. The call may be diverted to the telephone hybrid by pressing either the front panel mounted line connect switch or by means of the remote divert switch (if connected).

Alternatively, the incoming calls can be answered automatically by enabling the integrated ringing detector. It is recommended that the K-break line clearance is used when the ringing detector is enabled. When the ringing detector is in use, ringing tone will illuminate the line connect switch. The line connect switch lamp is off in the non-connected mode and illuminated in the connected mode.

Note: The remote lamp tally mimics the front panel line connect switch lamp, i.e. it flashes when ringing and is on when the line is held.

The hybrid unit will now behave as a 4 wire to 2 wire converter with signal inputs at the mic/line Input connector and telephone signal output at the output connector.

The call may be cleared by repressing the line connect switch or by means of the remote divert switch. The call can also be cleared automatically by enabling either the K-break disconnect or the dial tone disconnect (using the optional HY-03DTD dial tone disconnect plug-in PCB).

With both auto-answer and auto-clearance in use, call handling can be completely automatic in operation.

Making a Call

To initiate a call, lift the handset and dial the required telephone number. When the call has been established, press the line connect switch and the call will be handed over to the telephone hybrid unit. To clear the line at the end of the call, press the line connect switch. The line connect switch lamp is off in the non-connected mode and illuminated in the connected mode.

FAQ (Frequently Asked Questions)

The answers to most of the following questions are available elsewhere in the handbook, but have been summarised here for convenience.

Q: What are the remote connection details for these units ?

A: The remote connector is a 9-way female (socket) 'D' type. To remotely divert, connect pin 1 to pin 2. Pin 3 supplies +15V with reference to pin 4. The remotes can act as momentary or latching depending on the setting on the rear panel of the unit:

Pin 1: Divert switch (Line Connect)

Pin 2: Common

Pin 3: Lamp

Pin 4: Common

Q: What type of remote lamp will the HY-03 drive?

A: The remote lamp type should be 15V at 40mA max. **When connecting any loads the current should be limited to this value using a series resistor. For example a 390 ohm resistor would limit the current to 38mA.**

To connect/disconnect the unit pins 1 and 2 should be connected together via a contact closure or equivalent. Care should be taken that pin 3 is not connected to pins 1 or 2 and that incompatible external signals are not used. Incorrect configuration can result in the failure of the connect/disconnect transistor and protection diode which leaves the unit permanently latched in a connected state and therefore unusable.

As this fault is caused by using the unit outside of its recommended operating conditions it will not be covered under warranty.

Q: What is the power consumption of the HY-03 telephone hybrid?

A: <6W for HY-03 and HY-03S.

Q: What functions are controlled by the configuration settings switches on the rear panel of the HY-03 telephone hybrid?

A: SW1 – Dial Tone Disconnect Enable.

SW2 – K-Break Disconnect Enable.

SW3 – Input/Output Mix Enable.

SW4 – Ring Detector (Auto-Answer) Enable.

Q: The telephone hybrids don't automatically disconnect on dial-tone.

Why not ?

A: Whilst the HY-03 does include K-break disconnection (for the UK) and line polarity reversal (for the US), these do not use the dial tone to disconnect. There is no dial tone disconnection unless the HY-03DTD dial tone detect option has been added. If the HY-03DTD option has been added and you still have this problem, then ensure that configuration switch SW1 is set to on. Also, ensure that the HY-03DTD option is of the correct type for your network connection. See the Dial Tone Disconnect section later in this handbook.

Q: The telephone hybrid unit keeps “dropping the line”. How can I stop this happening?

A: Firstly, try disabling the k-break function of the hybrid – set the SETTINGS switch SW2 to off. If you still have a problem once the k-break is disconnected, please contact Sonifex technical support (technical.support@sonifex.co.uk)

Q: The signal input to the HY-03 at the input connector, is audible at the output. Why is this happening ?

A: There is an option on the HY-03 which enables the input signal to be mixed with the output. Ensure the SETTINGS switch SW3 is set to off to disable this option.

2 Configuration & Controls

Front Panel Controls



Figure 2-1: Front Panel Controls

Power LED Indicator

The power LED indicates that the equipment is powered and operational when illuminated.

Line Connect Switch

This is the front panel button used to connect calls to, and disconnect calls from, the telephone line. The switch will illuminate to indicate the call has been connected. If the integrated ring detector is enabled, the line connect switch will flash when an incoming call is detected. Operation of this switch can be remotely controlled.

Rear Panel Controls

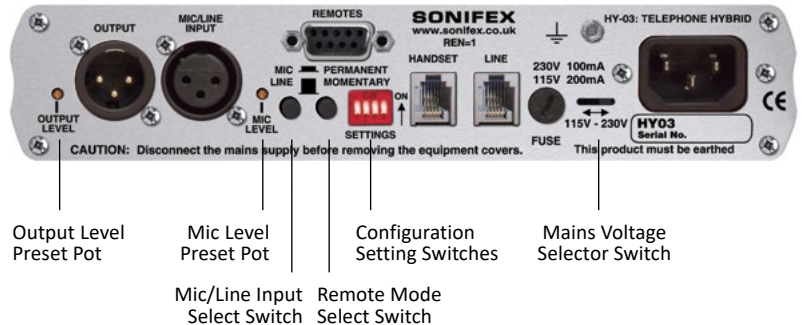

Figure 2-2 : Rear Panel Controls

Adjusting the Output Level

The Output Level Preset Pot controls the level of the output signal. Use a jeweller's screwdriver to adjust the gain of the output stage by +8dB to -14dB to give 0dB signals at the output.

Adjusting the Microphone Gain Level

The Mic Level Preset Pot controls the level of the input signal when the input signal mode is set to Mic. The input signal level in Line mode is factory set and is not affected by this control. The Mic Input will accept 200 ohm microphone level signals and is balanced/floating with a maximum gain of 74dB. Use a jeweller's screwdriver to adjust the gain between 74dB and 40dB.

Mic/Line Input Select Switch

This push-button switch sets the input signal mode :

Switch depressed (down) - Mic input mode selected

Switch not depressed (up) - Line input mode selected

Remote Mode Select Switch

This switch determines the operation of the remote line connect switch, if connected:

Switch depressed (down) - Permanent (latching) mode selected

Switch not depressed (up) - Momentary mode selected

Configuration Settings Switches

These switches are used to configure the HY-03 in the modes that you want it to operate.

A label on the top panel of the unit shows the orientation of the switches :

HY-03 SETTINGS		
1	ON	DIAL TONE DISCONNECT ENABLE
2	ON	K-BREAK DISCONNECT ENABLE
3	ON	INPUT / OUTPUT MIX ENABLE
4	ON	RING DETECTOR ENABLE

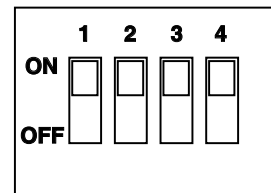

Figure 2-3 : Configuration Settings Switches

Dial Tone Disconnect Enable - SW1

When enabled (ON), the HY-03 will automatically disconnect from the telephone line when an appropriate dial tone is detected. See "Using the Dial Tone Disconnect option" later in this section.

Note: This feature is an optional extra and requires an additional plug-in PCB to be fitted. Please contact Sonifex for further information and pricing on the HY-03DTD board.

K-Break Disconnect Enable - SW2 and JP4

When SW2 is enabled (ON) (and for serial number HY-03 units after HY000323 when JP4 is on), the HY-03 will automatically disconnect from the telephone line by detecting the K-break. The K-break signal only operates in the UK and is available on nearly all electro-mechanical exchange systems. The signal consists of a momentary disconnection or significant reduction in current (to below 1mA) lasting from about 1ms to 100ms (modern design exchange systems are designed to have a K-break signal lasting 50ms). British Telecommunications plc may, in some situations where no end of call signal is available, be able to provide one at the request of a UK customer.

Line Polarity Reversal Disconnect Enable - SW2 and JP5

When SW2 is enabled (ON) (and for serial number HY-03 units after HY000323 when JP5 is on), the HY-03 will automatically disconnect from the telephone line by detecting the line polarity reversal. Line polarity reversal operates in the US and Canada and consists of a momentary reversal of the line polarity. Once a call is completed, polarity reversal happens on the line 3 times, each separated by a 10 second gap.

Input/Output Mix Enable - SW3

When this switch is enabled (ON), the HY-03 output signal will be an equal mix of the normal output signal and the selected input signal, either Mic or Line. This is useful if, for example, you want to use the HY-03 output to record both sides of the conversation.

Ring Detector (Auto Answer) Enable - SW4

This switch enables the integrated ring detector, which automatically answers incoming calls after a predetermined number of rings. The ringing detector circuits are on-line before and during the ringing cadence and are switched off-line during call holding.

Mains Voltage Selector Switch

This is used to configure the HY-03 operating voltage as either 115V, or 230V. The switch is recessed so that it can not be accidentally altered.

Note: The fuse will need to be changed if you alter the voltage settings.

HY-03 Internal Controls & Adjustments

See page iv for information on opening the HY-03.

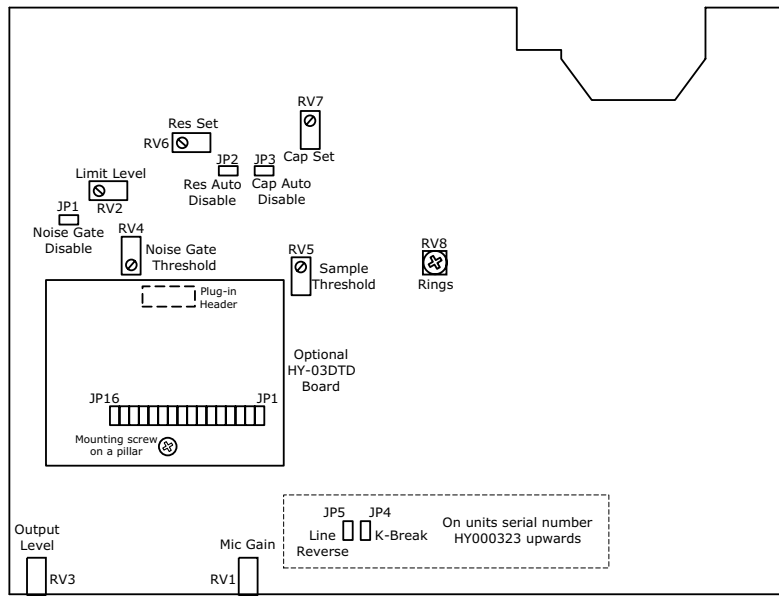

Figure 2-4 : HY-03 Preset Controls and Alignments

Setting the Number of Rings for The Ringing Detector

To alter the number of rings that occur before the ringing detector auto answers the call, use a jeweller's screwdriver to adjust RV8. The equipment is factory set for 3 rings, but this can be adjusted between 1 and 6 rings.

Note: The number of rings above are for UK ring tones and may vary for non-UK telephone exchanges.

Switching the Noise Gate On/Off

An output noise gate operates when the telephone signal is below the noise gate threshold control. This noise gate reduces the output gain by 34dB under no signal conditions eliminating the affects of telephone line cross talk. The noise gate can be switched off if you don't wish to use it by adding JP1 on the main circuit board.

JP1 ON – Noise Gate Off

JP1 OFF – Noise Gate On

Adjusting the Noise Gate Threshold

The noise gate is factory set to -26dBu to avoid interaction with the equipment null. To adjust the noise gate threshold, use a jeweller's screwdriver to adjust RV4 on the main HY-03 circuit board.

Note: The noise gate threshold is factory set for optimum performance, so will not normally need adjustment.

Important Note: There are a number of other controls which are factory set, or should only be used when testing/aligning the product. These are RV2, RV5, RV6, RV7 and jumpers JP2 and JP3. Please note that these controls should not be adjusted in normal operation and could damage the performance of your product if altered. Adjusting these settings will invalidate the warranty on your product.

Using the Dial Tone Disconnect Option

The optional HY-03DTD Dial Tone Disconnect PCB allows the HY-03 to drop a call automatically when the pre-configured tones are detected.

To use Dial Tone Disconnect, SW1 on the rear panel must be set to on, and the appropriate jumper(s) JP1-JP16 on the Dial Tone Disconnect PCB must be fitted to enable detection of the required tone(s). For example, to enable the HY-03 to detect the dial tone in Finland, set the rear panel SW1 to ON and set the jumpers on the HY-03DTD board over JP1, JP2 and JP3.

If the HY-03DTD board has been supplied for you to upgrade your HY-03, fit the correct jumpers on the board as below, follow the instructions on page 7 for opening the unit and plug it in, as per Figure 2-4. Make sure that there is a secure and firm connection between the plug-in headers, and fit the supplied threaded M3 x 12mm pillar between the two boards using the supplied M3 x 6mm pan head posidrive screws (one bottom and one top). Replace the HY-03 main board into the HY-03 chassis.

See Table D on the following page for a list of the tones currently implemented.

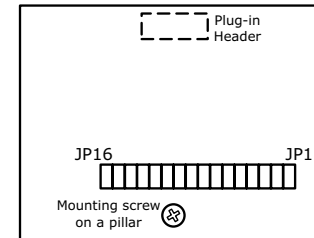

Figure 2-5 : Jumper settings on the HY-03DTD board

County	Frequencies	Type	Details	Jumper(s) set on JP...
Austria	440Hz	Continuous	-	1
Avaya PBX	400Hz	Cadence	375ms on, 375ms pause	2 + 3 + 4 + 5
Belgium	450Hz	Continuous	-	2
Bulgaria	425Hz	Cadence	250ms on, 750ms pause, 750ms on, 1000ms pause	1 + 2
Cyprus	350Hz and 450Hz	Continuous	-	3
Czech Republic	425Hz	Continuous	-	1 + 3
Denmark	425Hz	Continuous	-	2 + 3
Finland	425Hz	Continuous	-	1 + 2 + 3
France	440Hz	Continuous	-	4
Germany	425Hz	Continuous		1 + 4
Greece	440Hz	Continuous		2 + 4
Hungary	440Hz	Continuous		1 + 2 + 4
Iceland	425Hz	Continuous		3 + 4
India	400Hz	Cadence	750ms on, 750ms pause	1 + 3 + 4 + 5
Ireland	400Hz and 450Hz	Continuous		1 + 3 + 4
Israel	400Hz	Continuous		1 + 4 + 5
Italy	425Hz	Cadence	200ms on, 200ms pause, 600ms on, 1000ms pause	2 + 3 + 4
Italy2	425Hz	Cadence	200ms on, 200ms pause	1 + 2 + 3 + 4 + 5

2 Configuration & Controls

County	Frequencies	Type	Details	Jumper(s) set on JP...
Japan	400Hz	Continuous		2 + 4 + 5
Luxembourg	425Hz	Continuous		1 + 2 + 3 + 4
Netherlands	450Hz	Continuous		5
Norway	425Hz	Continuous		1 + 5
Poland	425Hz	Continuous		2 + 5
Portugal	425Hz	Continuous		1 + 2 + 5
South Korea	350Hz and 440Hz	Continuous		1 + 2 + 4 + 5
Spain	425Hz	Continuous		3 + 5
Sweden	425Hz	Continuous		1 + 3 + 5
Switzerland	425Hz	Continuous		2 + 3 + 5
Taiwan	350Hz and 440Hz	Continuous		3 + 4 + 5
United Kingdom	350Hz and 440Hz	Continuous & Cadence	750ms on, 750ms pause	1 + 2 + 3 + 5
United States	440Hz and 480Hz	Continuous		4 + 5

Table D : Dial tone disconnect options

The unit can be programmed with other settings, so please contact us if you need the settings for a different country to be implemented. In this case, it would be useful to have an audio recording of the dial-tone and a specification of the dial tone parameters.

3 Technical Specification

HY-03 Connection Details

All of the connections are located on the rear of the HY-03 :

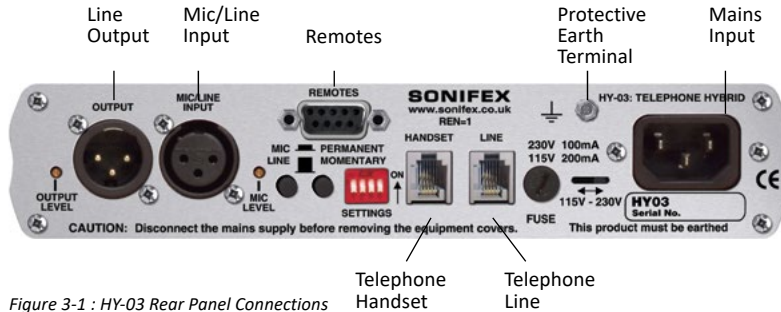

Figure 3-1 : HY-03 Rear Panel Connections

Line Output

The line output is an XLR 3 pin male connector (XLR-3-32, 50 ohm balanced floating).

- Pin 1: Screen
- Pin 2: Phase
- Pin 3: Non-phase

Mic/Line Input

The line input is an XLR 3 pin female connector (XLR-3-31, 10k ohm balanced floating).

- Pin 1: Screen
- Pin 2: Phase
- Pin 3: Non-phase

Remotes

The remote connector is a 9-way female (socket) 'D' type. To remotely divert, connect pin 1 to pin 2. Pin 3 supplies +15V (up to a maximum

of 40mA), with reference to pin 4. The remotes can act as momentary or latching depending on the setting on the rear panel of the unit.

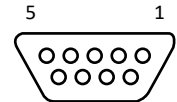

Pins viewed from rear of plug (or front of socket on unit)

- Pin 1: Divert switch (Line Connect)
- Pin 2: Common
- Pin 3: Lamp
- Pin 4: Common

The remote lamp tally mimics the front panel line connect switch lamp, i.e. it flashes when ringing and is on when the line is held.

Please note the Lamp output is only capable of driving loads up to 40mA , when connecting any loads the current should be limited to this value using a series resistor. For example a 390 ohm resistor would limit the current to 38mA.

To connect/disconnect the unit pins 1 and 2 should be connected together via a contact closure or equivalent. Care should be taken that pin 3 is not connected to pins 1 or 2 and that incompatible external signals are not used. Incorrect configuration can result in the failure of the connect/disconnect transistor and protection diode which leaves the unit permanently latched in a connected state and therefore unusable.

As this fault is caused by using the unit outside of its recommended operating conditions it will not be covered under warranty.

Telephone Handset

This is the connection for a telephone handset and is an RJ11 socket. There is a converter supplied with the HY-03 for accepting a standard BT605A telephone plug.

Telephone Line

This is the telephone line connection and is an RJ11 6/4 socket. Two cables are supplied with the unit, to connect this either to a UK BT line jack socket, or an RJ11 socket. The telephone line is connected via Pins 3 and 4 on the RJ11 and Pins 2 and 5 on the BT Plug (the latch adjacent to Pin 6).

RJ11 Telephone Connections

Pin 1 : N/C

Pin 2 : Earth recall

Pin 3 : Telephone line A

Pin 4 : Telephone line B

Pin 5 : Ringer

Pin 6 : N/C

BT Telephone Connections

Pin 1 : N/C

Pin 2 : Telephone line A

Pin 3 : Ringing

Pin 4 : Connected for neatness only

Pin 5 : Telephone line B

Pin 6 : N/C

RJ11 Socket

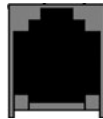

Pin 6 Pin 1

BT Plug

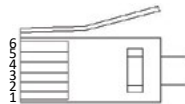

Note: When not used in the UK, connect pins 3 and 4 only for operation.

Mains Input

The power supply is connected via an IEC Connector (CEE22, 230V - 50Hz, or 115V - 60Hz).

Protective Earth Terminal

This earth bond screw terminal is a screen terminal which must be connected to an earth point.

Technical Specification

Feature	Value
Input impedance – line mode (clean feed):	10k Ω balanced 0dB, optimum working input level 0 to +8dBu
Input impedance – microphone mode:	2k Ω balanced
Clean feed limiting input:	+4dBu
Microphone level range:	From 74dB to 40dB adjusted by preset pot
Bandwidth to telephone line:	250Hz – 4kHz, -3dB ref 1kHz
Telephone line impedance:	Nominally 600 Ω
Telephone line impedance range:	300 Ω to 1500 Ω
Output impedance:	50 Ω balanced floating 0dBu
Output level range:	+8dB to -14dB adjusted by preset pot
Rejection ratio:	45dB on 1kHz tone, typically 28dB on complex waveforms, reference peak level of 0dB
Ring detector sensitivity:	1 ring to 6 rings
Power:	230V 50Hz, or 115V 60Hz. 6W for HY-03.

Physical Specification

Order Code	Description	Height	Width	Depth*	Total Nett Weight	Total Gross Weight
HY-03	Automatic analogue TBU with ringing detector, free standing	4.5cm	21.8cm	17.5cm	1.25kg	2.0kg
HY-03S	Automatic analogue TBU with ringing detector, 19" rack mounted	4.5cm (1U)	48.3cm (19" rack width)	17.5cm	1.30kg	2.1kg
HY-03T	Twin automatic analogue TBU with ringing detector, 19" rack mounted	4.5cm (1U)	48.3cm (19" rack width)	17.5cm	2.60kg	4.0kg

*Depth is measured from the front of the divert button to the back of the remotes connectors.

Accessories

Order Code	Description
HY-03DTD	Dial tone detect add-on board
HY-03CON	Front panel conversion kit, HY-03S 19" rack-mount front to HY-03 free standing
HY-03SCON	Front panel conversion kit, HY-03 free standing to HY-03S 19" rack-mount front
HY-03TCON	Front panel conversion kit, HY-03 or HY-03S, to HY-03T 19" rack-mount front

Approvals Information

Sonifex is a BABT approved manufacturing facility with a license to build telecommunications equipment and all telecom products are compliant with BS6301, BS7002, BS415 and CTR21. The following product description is necessary for BABT approval and provides information on the connection and operating conditions of the units.

Manufacturer

Sonifex Limited,
61 Station Road,
Irthlingborough,
Northants,
NN9 5QE
United Kingdom

Equipment Type

HY-03 telephone balance unit.

BABT Approval Numbers

HY-03 : S/3619/23/L/501792

Functions

The HY-03 Telephone Balance Unit is suitable for connection to B.T. exchange lines with a series connected telephone at the handset port. The hybrid unit is used as a four wire to two wire converter. Incoming calls received at the handset may be diverted to the hybrid unit and produce a 'telephone' signal at the output of the unit. Signals presented at the input are transmitted to the telephone line only. The HY-03 automatically balances the telephone line.

Specified Systems

The HY-03 is suitable for connection to any exchange line forming part of a Public Switched Telephone Network, PSTN, or a Relevant Branch system for PSTN lines or any extension. This equipment is not suitable as an extension to a payphone. A definition of Relevant Branch System for PSTN is given in BS6789 : Section 6.1 : 1986 Clause 2.9; including the note to that clause.

Ringer Equivalence Number

The REN=1 marking on the rear of this equipment relates to the performance of the apparatus when used in combination with other items of apparatus.

The REN indicates the maximum number of items that should be connected simultaneously to the line. This equipment may be connected with series apparatus up to REN = 4 maximum.

Accessory Ports

Barrired Ports - The Handset series connection complies with BS6301
Accessory Ports - Mic/Line Input
Output
Remotes

Conditions

This apparatus is not designed for use under controlled conditions of temperature and relative humidity.

Series Connection

When connected into the loop connection between the main apparatus and the PSTN, this apparatus introduces a voltage drop at a current of 40mA of 0.300V.

The apparatus should not be used in conjunction with other series connected apparatus such that the aggregate declared voltage drops, together with that of any relevant wiring at 40mA, exceeds 2.0 volts.

Facilities

This apparatus has been approved for use as a telephone hybrid unit (four wire to two wire converter) and for use with a series connected simple telephone. Any other usage will invalidate the approval of the apparatus if as a result it then ceases to comply with the standards against which approval was gained.

Statutory Mark

Approved for connection to telecommunications systems specified in the instructions for use subject to the conditions set out in them.

SONIFEX

www.sonifex.co.uk

t:+44 (0)1933 650 700

f:+44 (0)1933 650 726

sales@sonifex.co.uk